



Installation, Operation and Maintenance Manual: 800T5 Series

800T5 Series

REVISION REGISTER

Version	Details of Update	Date
1	Original document creation	4/13/2015
2	Updated nomenclature; temporarily removed selection guide pages	6/30/2016

Table of Contents

Section 1: Product Specification	3
Section 2: System Layout.....	15
Section 3: Installation Instructions.....	17
Section 4: Plug-in Insertion Instructions	23
INSTALLING A PLUG-IN UNIT.....	24
REMOVING A PLUG-IN UNIT	27
PLUG-IN DISTANCE CLEARANCES:	28
Section 5: Product Warranty Details	35
Section 6: Maintenance	38

Section 1: Product Specification

1.01 SUMMARY

- A. This specification covers the electrical characteristics and general requirements for a track busway system, hereafter referred to as (Track Busway). The system shall be designed primarily for overhead distribution of electrical power. Supporting designated

work areas and equipment. Once installed the Busway will provide a simple, versatile, fast and economic means of distributing power. Loads fed from a variety of plug-in units can be easily added or removed without shutting power down to the busway.

1.02 STANDARDS AND CERTIFICATION

- A. The Track Busway shall be designed and manufactured to the following standards:
1. Underwriters Laboratories Standard, UL 857 – The common UL, CSA, and ANCE Standard for Busways that is derived from the fifth edition of CSA Standard C22.2 No. 27, the twelfth edition of UL 857, and the second edition of NMX-J-148-1998-ANCE.
 2. Low Voltage Switchgear and Controlgear Assemblies, Part 1: Type Tested and partially type tested Assemblies, IEC 60439-1: 1999.
 3. Low Voltage Switchgear and Controlgear Assemblies, Part 2: Particular Requirements for Busbar Trunking systems (Busways), IEC 60439-2: 2000.Low Voltage Directive (73/23/EEC) including Amendment (93/68/EEC).
 4. ETL Certified (US/Canada) to UL857
 5. National Electric Code (NEC) – Article 368 – Busways
 6. NEMA AB1, Molded Case Circuit Breakers and Molded Case Switches
 7. NEMA KS-1, Enclosed and Miscellaneous Distribution Equipment Switches (600VAC).
 8. NFPA 70 – National Fire Protection Agency

1.03 SYSTEM DESCRIPTION

- A. Electrical Requirements

STARLINE Track Busway

Manufactured by:

Universal Electric Corp.
168 Georgetown Rd.
Canonsburg, PA 15317
(724) 597-7800

Voltage: 600V AC and DC

Frequency: 50/60 Hz

Ampacity: 800A

Neutral Ampacity: 800A

Conductors: 3 Phase conductors, 1 Neutral Conductor

Copper: Solid Copper, Nickel Plated

Composite: Continuous nickel plated Copper contact surface within nickel plated aluminum busbar

Grounding: Aluminum Casing

System Designation:

System	Amperage	Neutral	Iso Ground
800T5CC	800	800	No
800T5GCC	800	800	Yes
800T5CA	800	800	No
800T5GCA	800	800	Yes

B. Environmental

Indoor, Low Impedance System

<i>Elevated Ambient Temperature Operation of Starline Busway</i>					
<i>Temperature (°C)</i>					
	40	50	55	60	
<i>De-Rating Factor</i>					
System					
800T5	NONE	NONE	NONE	NONE	

- C. Indicate construction details, including dimensions, weights, clearances, major component layout, power details. Include circuit breaker, fused plug-in, and cable schedule (if applicable), including cable lengths and plug-in schedules.
- D. Include connection diagram for external wiring, and details of conduit and wiring connections and terminations.
- E. Indicate special receiving and handling procedures.
- F. Provide electrical characteristics and connection requirements for the system and accessories.

1.04 SUBMITTALS

- A. Submittals shall be in accordance with specified procedures. Submit shop drawing and product data for record purposes prior to shipment.
- B. Indicate construction details, including dimensions, weights, clearances, major component layout, power details. Include circuit breaker, fused plug-in, and cable schedule (if applicable), including cable lengths and plug-in schedules.
- C. Include connection diagram for external wiring, and details of conduit and wiring connections and terminations.
- D. Indicate special receiving and handling procedures.
- E. Provide electrical characteristics and connection requirements for the system and accessories.

1.05 WARRANTY

- A. The Track Busway manufacturer shall guarantee the entire system against defective material and workmanship for a period of one (1) year from date of shipment.

1.06 COMPONENTS

- A. Frame and Enclosure:
 - 1. Extruded Aluminum housing certified to serve as a 100% ground. Housings to be 5 or 10 ft standard length. This housing should be properly extruded with slots to receive rod mount hangers to hang from a ceiling. This housing should be open on the bottom to accept plug-in units anywhere along its length. This opening shall pass UL's hypothetical finger probe test.
 - 2. All conductors shall be made of copper or composite copper/aluminum and sized to handle 100% of it's rating continuously with ambient temperatures below 40°C / 104°F. The conductors shall be electrically isolated from the housing.
- B. Plug-in Units
 - 1. Plug-in units shall be polarized to avoid incorrect installation.
 - 2. Plug-in units shall use [{"circuit breakers"} {"fuses"}] for branch circuit protection.
 - 3. Plug-in units shall have locking clips or bolt-on tabs to secure units to the busway.
 - 4. Plug-in units that include drop cords shall be manufactured with cord grips and receptacles as specified in the drawings.

1.07 INSTALLATION

- A. Track Busway Sections – The runs will consist of lengths as shown on the drawings.
- B. Hanging of the Track Busway – Using supplied ‘Rod Mount Hangers’ the busway will be hung from the ceiling using all thread. The installing contractor shall be responsible for the connections on the ceiling end. The supplied Rod Mount Hangers will connect the track busway to the all thread. The maximum spacing is 10 ft on center for the hangers. The height of the track busway shall be coordinated with the Architect.
- C. Connecting Sections of Track Busway – At a junction of Track Busway sections, the installer will install the top housing coupler; the bus connector is inserted, centered and seated in the slot of the Busway. The installation tool is inserted into jointed intersection and rotated 90 deg. Forcing stabs into u-shaped female conductors. Housing coupler is positioned over the bottom joint and tightened. A manufacturer supplied tool will assist in joining sections together.
- D. End of Runs – End caps will be provided to install at the ends of each run
- E. Closure Strip – The closure strip can be cut and fitted to cover the bottom opening of the Track Busway housing to prevent dust and debris from gathering in the Track Busway (if applicable).

Supply as manufactured by Universal Electric Corporation; 168 Georgetown Rd; Canonsburg, PA 15317; (800) 245-6378; (724) 597-7800; fax (724) 916-2221. No known equal.

SECTION 26xxxx – BUSWAY SYSTEM

PART 1- GENERAL

1.1 RELATED DOCUMENTS

- A. Drawings and general provisions of the Contract, including General and Supplementary Conditions and Division 01 Specification Sections, apply to this Section.
- B. The Busway System shall be designed and manufactured to the following standards:
 - 1. Low Voltage Directive (73/23/EEC) including Amendment (93/68/EEC)
 - 2. Low Voltage Switchgear and Controlgear Assemblies, Part 1: Type Tested and partially type tested Assemblies, IEC 60439-1: 1999
 - 3. Low Voltage Switchgear and Controlgear Assemblies, Part 2: Particular Requirements for Busbar Trunking systems (Busways), IEC 60439-2: 2000
 - 4. Underwriters Laboratory Standard, UL 857 – The common UL, CSA, and ANCE Standard for Busways that is derived from the fifth edition of CSA Standard C22.2 No. 27, the twelfth edition of UL 857, and the second edition of NMX-J-148-1998-ANCE.
 - 5. CUL Listing
 - 6. National Electric Code (NEC) – Article 364 – Busways
 - 7. NEMA AB1, Molded Case Circuit Breakers and Molded Case Switches
 - 8. NEMA KS-1, Enclosed and Miscellaneous Distribution Equipment Switches (600VAC)
 - 9. NFPA 70 – National Fire Protection Agency

1.2 SUMMARY

- C. This specification covers the electrical characteristics and general requirements for a Busway System, hereafter referred to as Busway. The system shall be designed primarily for overhead power distribution of electrical power. Loads fed from Plug-in units can be added or removed without shutting down the Busway.
- D. Section Includes:

1. Three-phase Busway System with the following features:
 - a. Power Feed
 - b. Extruded aluminum busway housing with conductors
 - c. Miscellaneous hardware for system installation
 - d. Installation tool
 - e. Plug-in units for power distribution
 - f. Monitoring

1.3 DEFINITIONS

- E. EMI: Electromagnetic interference.
- F. LED: Light-emitting diode.
- G. PC: Personal computer.
- H. THD: Total harmonic distortion.

1.4 ACTION SUBMITTALS

- I. Product Data: For each type of product indicated. Include data on features, components, ratings, and performance.
- J. Shop Drawings: For Busway include:
 1. Detail equipment assemblies and indicate dimensions, weights, and location and identification of each field connection.
 2. Wiring Connection: For power and monitoring wiring.
 3. Orientation of Plug-In units face in final installation.
 4. Include Plug-In Schedule with detailed description.

1.5 INFORMATIONAL SUBMITTALS

- K. Manufacturer Certificates: For each product, from manufacturer.

1.6 CLOSEOUT SUBMITTALS

- L. Operation and Maintenance Data: For Busway System include in operation and maintenance manuals.

1.7 MAINTENANCE MATERIAL

- M. Furnish extra materials that match products installed and that are packaged with protective covering for storage and identified with labels describing contents.
 - 1. Plug-in Units: **[One]** <Insert number> for every **[10]** <Insert number> of each type and rating, but no fewer than **[one]** <Insert number> of each.

1.8 QUALITY ASSURANCE

- N. Source Limitations: Obtain Busway and Plug-in Units through one source from a single manufacture.
- O. Electrical Components, Devices, and Accessories: Listed and labeled as defined in NFPA 70, by a qualified testing agency, and marked for intended location and application.
- P. UL or ETL Compliance: Evaluated and Tested to UL857 standards
- Q. NFPA Compliance: Mark components as suitable for installation in computer rooms according to NFPA 75.

1.9 WARRANTY

- R. Warranty: The Busway manufacturer shall guarantee the entire system against defective material and workmanship for a period of one (1) year from date of shipment.

PART 2- PRODUCTS

2.1 MANUFACTURERS

- S. Basis of Specification is Starline Track Busway as manufactured by Universal Electric.

2.2 OPERATIONAL REQUIREMENTS

- T. Environmental Conditions: The Busway shall be capable of operating continuously in the following environmental conditions without mechanical or electrical damage, degradation or derating of operating capability.
 - 1. Ambient Temperature for Electronic Components: 32 to 104 deg F (0 to 40 deg C).
 - 2. Relative Humidity: 0 to 95 percent, noncondensing.
 - 3. Altitude: Sea level to 4000 feet (1220 m).

2.3 PERFORMANCE REQUIREMENTS

- U. The Busway shall perform as specified in this specification while supplying rated full-load current as shown on the project drawings.
- V. Voltage: Busway shall be rated 600V AC and DC, unless oversized N, in which case it will be rated 980V
- W. Frequency: DC to 60 Hertz
- X. Busway Amperage: As shown on Drawings

2.4 COMPONENTS

- Y. Power Feed
 - 1. The power feed shall provide the connections from the incoming cables to the Busway System. The Power Feed shall be a NEMA enclosure with access panels for incoming cabling. The Power Feed shall have internal connection to a section of Busway conductors.
- Z. Busway Frame and Enclosure
 - 1. Housing: The Busway housing sections shall be constructed of extruded aluminum and provide 100% system ground. The lengths provided on the project shall be as recommended and selected by the manufacturer to meet the project requirements in up to 15' sections. The top of the busway shall have a slot running the length of the busway to provide attachment points for installation of the Busway. The bottom of the Busway shall have a continuous opening to accept the Plug-in units. This opening shall pass the UL hypothetical finger probe test.
 - 2. Conductors: All conductors shall be made of 100% copper and sized to handle 100% of the Busway rating under continuous operation up to the maximum ambient temperature. The conductors shall be electrically isolated from the housing.
 - a. Isolated Ground: An isolated ground is to be supplied if shown on the drawings.
 - b. Oversized Neutral: An oversized neutral conductor shall be supplied if shown on the drawings
 - 3. Withstand Rating: The Busway shall meet the kA withstand rating shown on the drawings. If none is shown, the minimum acceptable is 35kA.
- AA. Installation Tool
 - 1. The installation tool provided by the manufacturer is to be used to make all joint connections between Busway sections and Power Feeds.

BB. Miscellaneous Hardware

1. End Cap: The End Cap is installed at the end of the Busway run.
2. Joint Kit or Bus Connector: The Joint Kit or Bus Connector is used to make electrical and mechanical connections between Busway sections and Power Feeds.
3. Busway Hangers: Busway Hangers are installed in the top slot of the Busway and provide for connections to the suspension system provided by the installing contractor.
4. Closure Strips: The open slot of the Busway for the 800A busway must be enclosed to prevent access to the conductors of the Busway. For smaller amperage Busway, this is to be provided only if shown on the drawings.

CC. Plug-In Units

1. Plug-in Units shall be polarized to avoid incorrect installation
2. Plug-in Units shall use either a circuit breaker or a fuse for branch circuit protection as shown in the schedule on the project drawings.
3. Plug-in Units shall have locking clips or bolt-on tabs to secure units to the Busway.
4. Plug-in Units that include drop cords shall be manufactured with cord grips and receptacles as specified on the schedule on the project drawings.
5. Plug-in Units shall not have a mechanism in order to engage the electrical connection to the busway conductors.
6. Plug-in Units shall be configured by the manufacturer to balance the load based on quantity of Plug-in Unit types provided.

DD. Monitoring (**OPTION**)

1. Power Feed Monitoring (**Option – Select as Required**): The Power Feed is to be provided with the following power measurements and remote monitoring interface.
 - a. Input Voltage (L/L and L/N)
 - b. Current per Phase (Min/Max)
 - c. Voltage per Phase (Min/Max)
 - d. Neutral Current
 - e. Power Factor

- f. Frequency
 - g. Power (Active, Reactive, Apparent)
 - h. Demand (kWH)
 - i. Current Peak Demand
 - j. Accuracy is better than 0.5%
 - k. Communications is Modbus RTU, Modbus TCP, SNMP, wireless, or BacNET
 - l. LED Display
2. Plug-In Unit Monitoring (**Option – Select as Required**): The Plug-In units as indicated on the schedule on the project drawings shall have the following power measurements and remote monitoring interface.
- a. Input Voltage (L/L and L/N)
 - b. Current per Phase (Min/Max)
 - c. Voltage per Phase (Min/Max)
 - d. Power Factor
 - e. Frequency
 - f. Power (Active, Reactive, Apparent)
 - g. Demand (kWH)
 - h. Current Peak Demand
 - i. Accuracy is better than 0.5%
 - j. Communications is Modbus RTU, Modbus TCP, SNMP, wireless, or BacNET

PART 3- EXECUTION

3.1 EXAMINATION

- EE. Examine areas and conditions, with Installer present, for compliance with requirements for conditions affecting performance of the Busway.
- FF. Proceed with installation only after unsatisfactory conditions have been corrected.

3.2 INSTALLATION

- GG. The contractor shall install the Busway in accordance with manufacturer's instructions.
 - 1. The Busway runs shall consist of lengths as shown on the drawings.
 - 2. The Plug-in units orientation shall be as indicated on the drawings.
 - 3. Hanging of the Busway shall be done using the Busway hangers from a structure above the Busway. The hangers shall connect to the Busway, and to an all thread rod provided by the installing contractor. The spacing of the hangers along the busway is 10 feet or less as recommended by the manufacturer.

4. The power feed shall have connection provisions for the contractor supplied feeder cabling. The power feed shall be connected to the Busway section using a joint kit or bus connector.
 5. Connection of sections of the Busway shall be done using a joint kit or bus connector. The connection shall be made per the manufacturer's instructions. The use of the manufacturer supplied Installation Tool is required.
 6. An End Cap shall be installed at the end of the Busway run.
 7. As shown on the drawings elbow or tee connections may also be required.
- HH. Maintain minimum clearances and workspace at equipment according to manufacturer's written instructions and NFPA 70.
- II. Connections: Contractor shall make connections to supply circuits according to manufacturer's instructions and project drawings.

3.3 GROUNDING

- JJ. The housing of the busway shall be the system ground.

3.4 IDENTIFICATION

- KK. Installing Contractor to identify components and wiring according to Section 260553 "Identification for Electrical Systems."

3.5 FIELD QUALITY CONTROL

- LL. Installing Contractor Inspections:
1. Comply with manufacturer's written instructions.
 2. Inspect interiors of enclosures, including the following:
 - a. Integrity of mechanical and electrical connections.
 - b. Component type and labeling verification.
 - c. Ratings of installed components.
- MM. Installing Contractor to prepare inspection reports.
- NN. END OF SECTION 26xxx

Section 2: System Layout

800T5 SYSTEM:

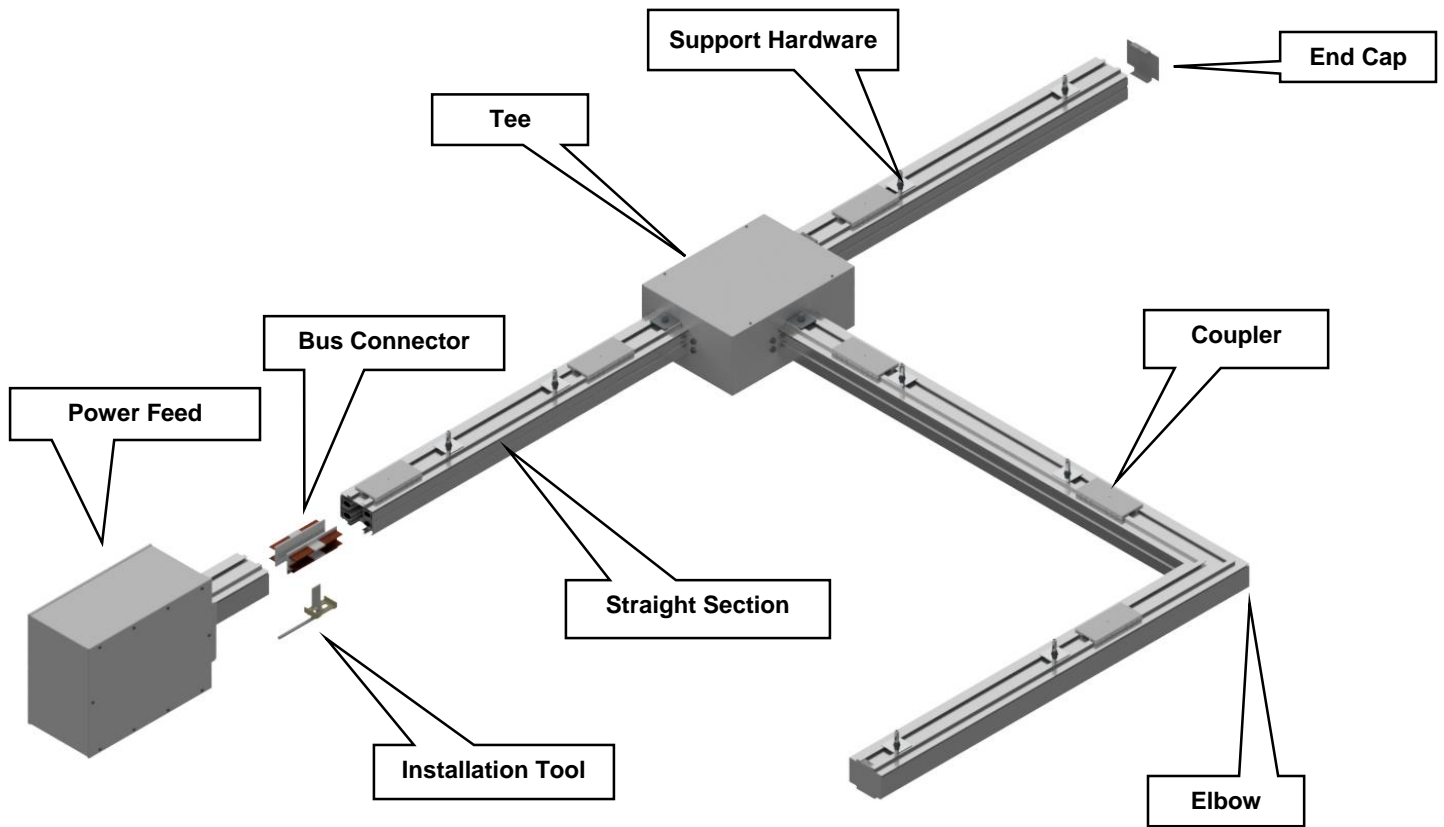

Section 3: Installation Instructions

FEED CONDUCTOR CAPABILITY

U.S.

FEED	PHASE LUG	NEUTRAL LUG	GROUND LUG (enclosure)	GROUND LUG (iso ground)
UF800T5C4 (CC & CA)	(2)600MCM	(2)600MCM	350MCM	N/A
UF800T5CG (CC & CA)	(2)600MCM	(2)600MCM	350MCM	350MCM
UF800T5C4 (quad lug) (CC & CA)	(4)600MCM	(4)600MCM	(2)350MCM	N/A
UF800T5CG (quad lug) (CC & CA)	(4)600MCM	(4)600MCM	(2)350MCM	350MCM
AF800T5C4 (CC & CA)	(4)600MCM	(4)600MCM	(2)350MCM	N/A

Metric

GROUND OPTIONS:
FAQ CASE GROUND, DEDICATED GROUND, ISOLATED GROUND

CASE GROUND

Uses aluminum housing and no extra copper bar.

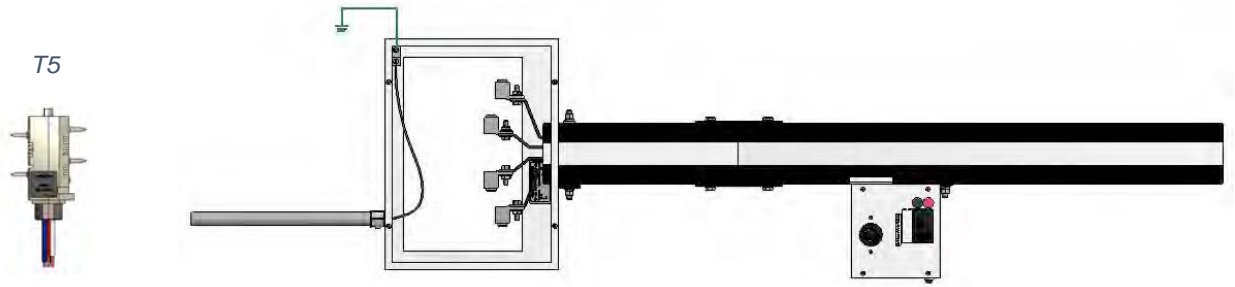

DEDICATED GROUND

Extra bar in busway for ground. Everything tied together inside plugs. Bar and housing at same potential.

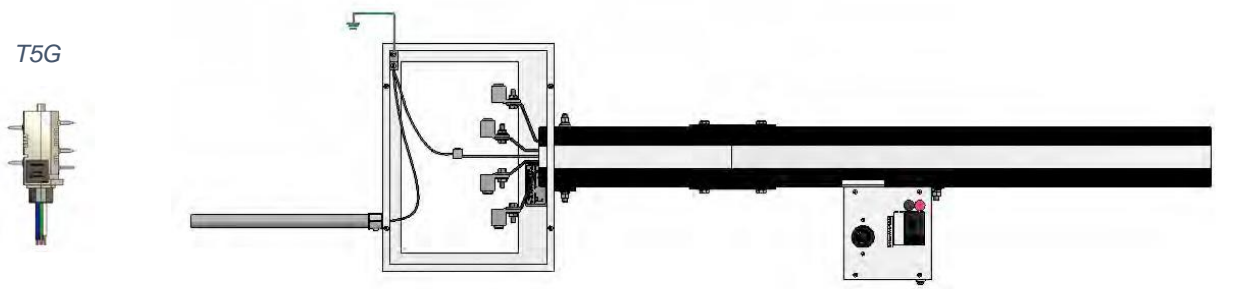

ISOLATED GROUND

Orange receptacles in plugs. Case ground isolated from copper ground bar. Isolated ground carried back to panel by others.

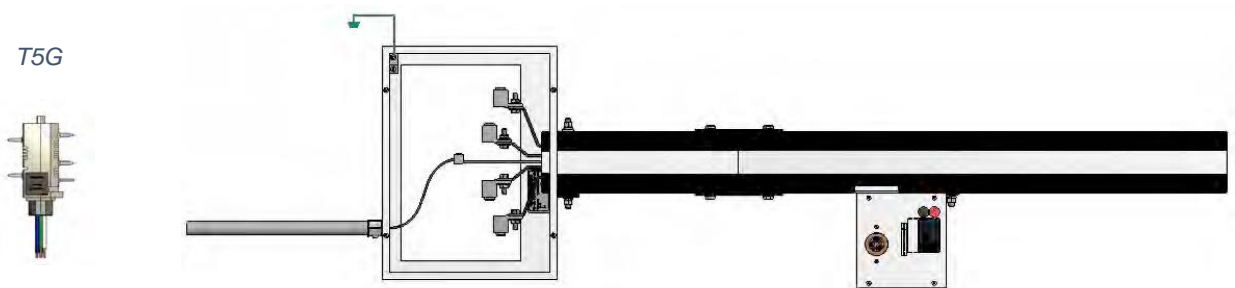

800T5 END FEED INSTALLATION

Warning: Make sure the power is off before making your wire connections inside the End Feed Box.

End Feed Units are used to make field wiring connections to the Busway at the end of a run. The End Feed box installs like a standard section. Wiring connections are made to the copper blades by means of aluminum box style lugs. For all versions, safety ground connection is made to the box with the lug provided. Isolated ground systems provide a separate, additional connection. The End Feed Box can be installed on the busway section before or after hanging the busway.

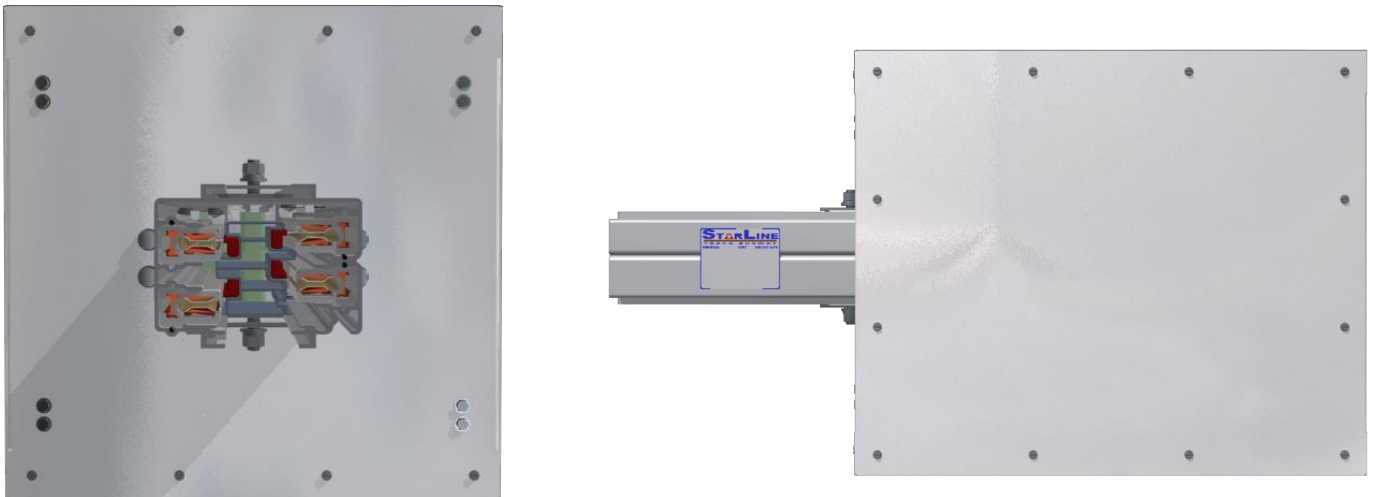

Field Wiring:

Remove the lug from the end feed block. Attach wire to lug. Reinstall back on block. In some cases it may be possible to install wire into the lug without removing the lug from the block. The lug is capable of accepting up to 2 600MCM cables. Secure by tightening the set screw to 275 in./lbs. Repeat for the remaining connections.

800T5 JOINT KIT INSTALLATION

In order to connect adjacent Busway sections one joint kit is required at each joint. Each kit is comprised of a housing coupler pair and bus connector set (pictured below).

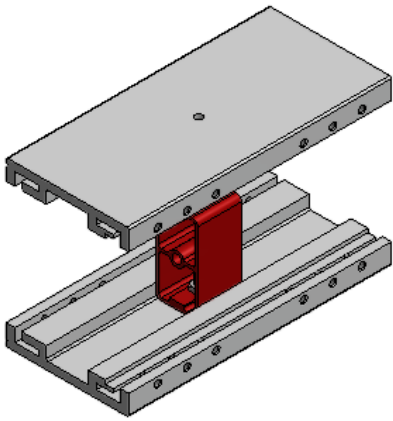

Figure 1: Housing Coupler

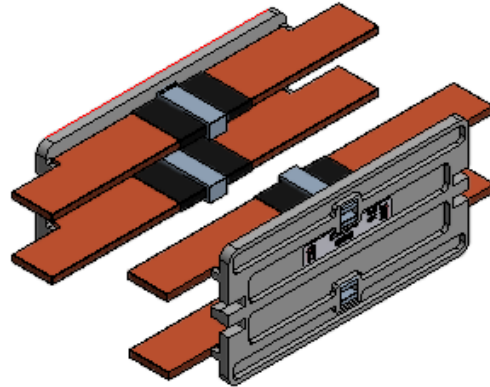

Figure 2: Bus Connector

Insert the pair of Housing Couplers onto one housing section. The housing coupler and the hanger channel of the Busway are polarized; ensure they are aligned before inserting them. Position the bottom coupler away from the joint, and align the Busway with the adjacent Busway section. Center the top housing coupler around the joint and tighten the set screws securely. Next, begin to install the bus connector kit by inserting the A-B Bus Connector inside the slot of the Busway. Ensure the connector is centered on the joint and push the Bus Connector in until secure. Insert the installation tool inside the slot of the Busway at the joint. Position the collar around the Busway housing so that the radius on the tool is positioned against the Bus Connector cover. Using the lever, rotate the installation tool and release. Work toward the end of the blade cover until the copper blades are firmly seeded into channels.

Repeat each of these steps for the other side of the Bus Connector. Remove the installation tool, center the bottom housing coupler, and tighten the 24 set screws.

For further assistance, refer to the installation video here:

https://www.youtube.com/watch?v=z6VAhU_yba4

HANGER BOLT INSTALLATION

There are two standard hanger options for mounting Starline Busway. UBRHT5-1 (Figure 1) is the standard hanger for supporting Starline busway via 1/2" threaded rod. UBHT5-1 (Figure 2) is most commonly seen when hanging via unistrut. At a minimum, hardware supports the busway at ten foot (3 meter) intervals. Once the hanger is placed in the mounting channel and the support hardware is installed, tighten down with 1/2" wrench.

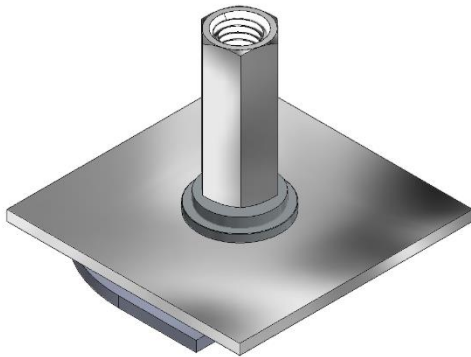

Figure 1: UBRHT5-1
(MBRHT5-M12)

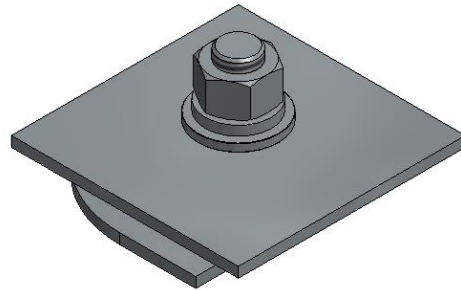
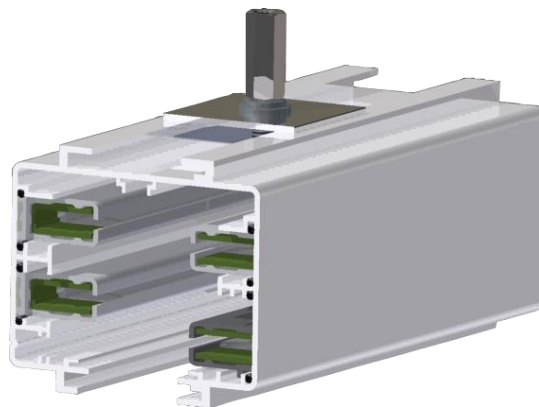

Figure 2: BHT5-1
(MBHT5-M12)



Section 4: Plug-in Insertion Instructions

INSTALLING A PLUG-IN UNIT

Before You Begin:

- Always wear appropriate PPE
- Please consult NFPA 70E for information on calculating incident energy for the location of your work, and the necessary associated PPE for your particular installation.



DO NOT install Plug-in units under load. Make sure breakers are in the off position

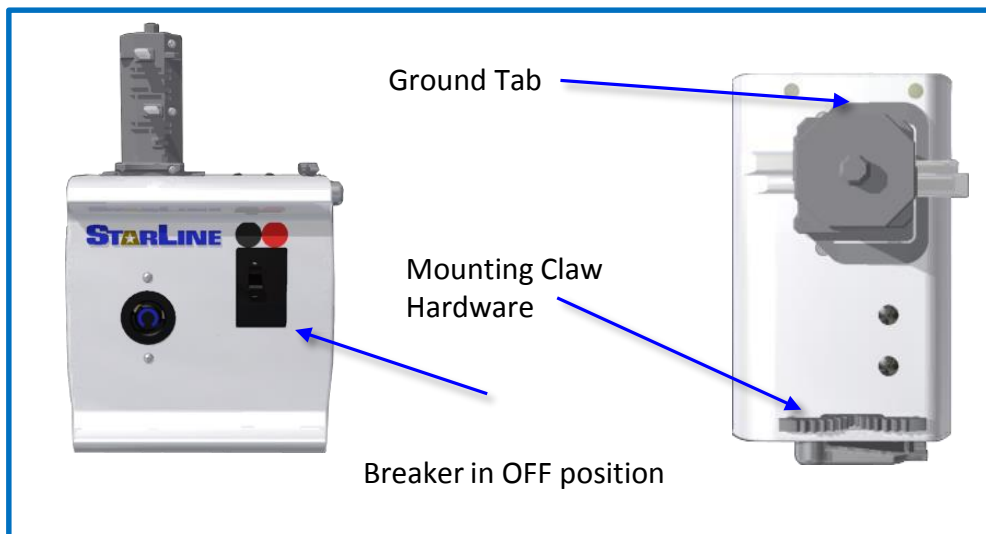

Step 1

Guide the paddle into the access slot of the busway



Step 2

Plug-Head inserted completely into busway

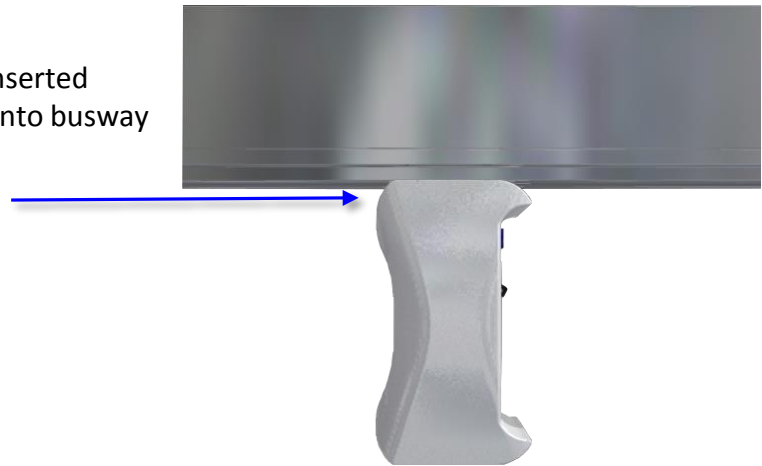

Step 3

Rotate so that the blades engage the busbars. **Enclosure firmly pressed up against busway** (*Hint: push UP against the busway as you begin to rotate clockwise.*)



Step 4

Rotate plug-in to the right until it is parallel to the busway

The typical circuit breaker/receptacle faces the direction of the polarizing strip for T5 systems.



Step 5

Engage lever to operate the mounting claw. If installing an older style plug, insert hanger bolt to mounting tab and securely tighten



Step 6

Rotate locking lever to secure the locking claw

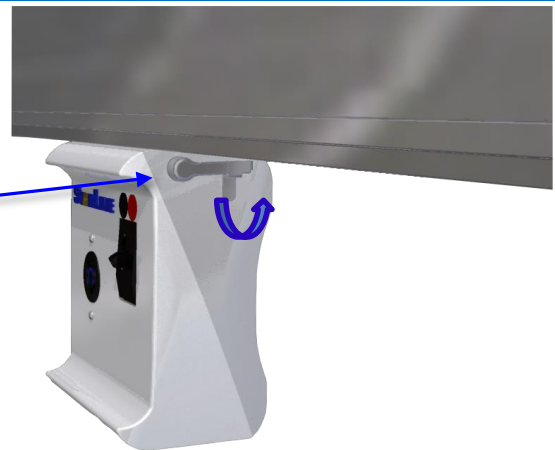

REMOVING A PLUG-IN UNIT

Step 1

Put breaker in off position.

DO NOT Remove under load



Step 2

Disengage locking lever

Rotate operating handle down retracting locking claw mechanism

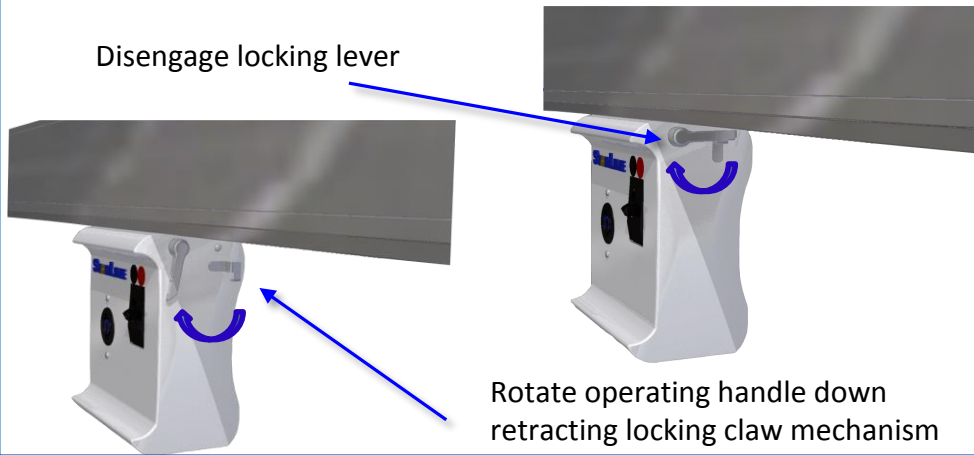

Step 3

Rotate the enclosure clockwise 90 degrees and pull down until the paddle is clear of the busway.



**PLUG-IN DISTANCE CLEARANCES:
SIDE DISTANCE CLEARANCE**

The following drawings show the side and height clearances of standard Universal Electric enclosures.

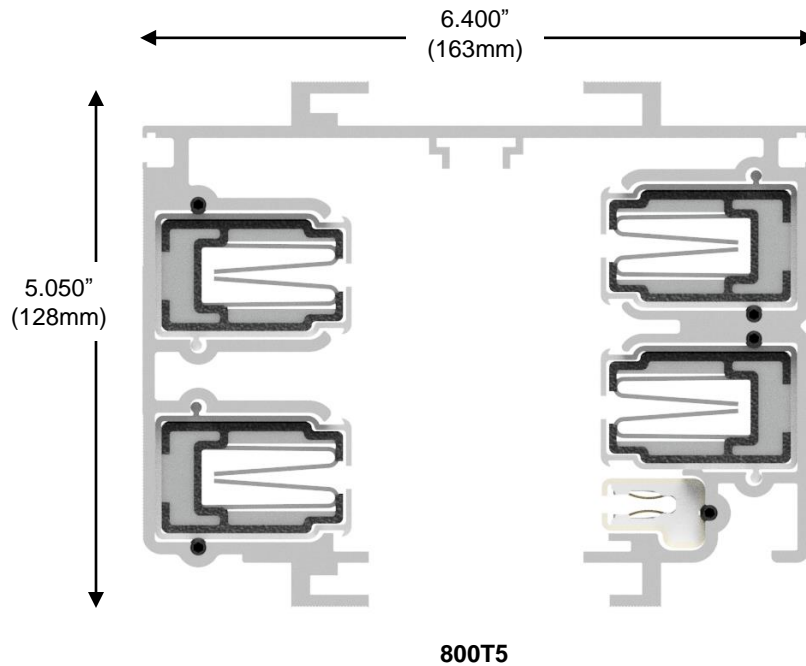
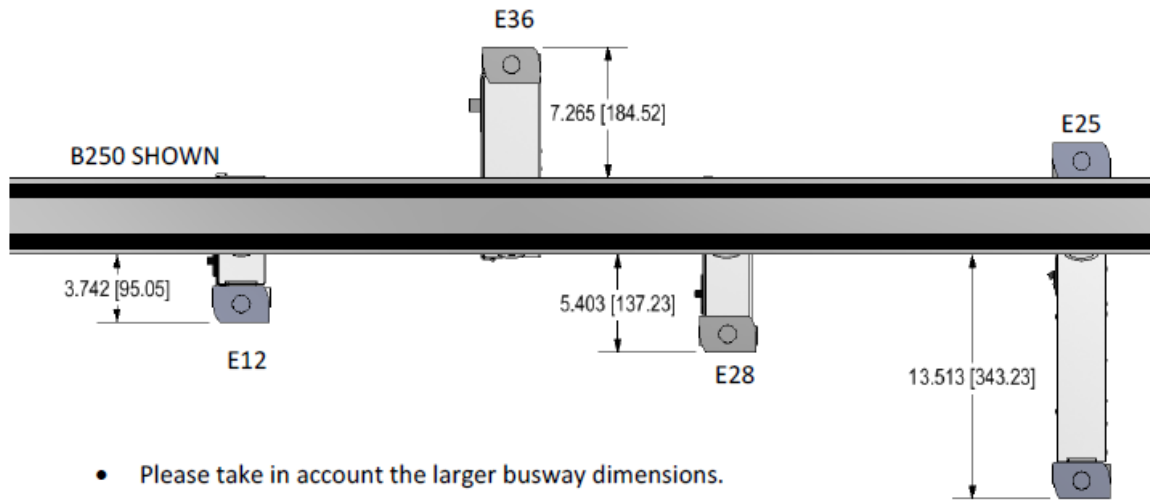

HEIGHT DISTANCE CLEARANCE
Enclosure E12

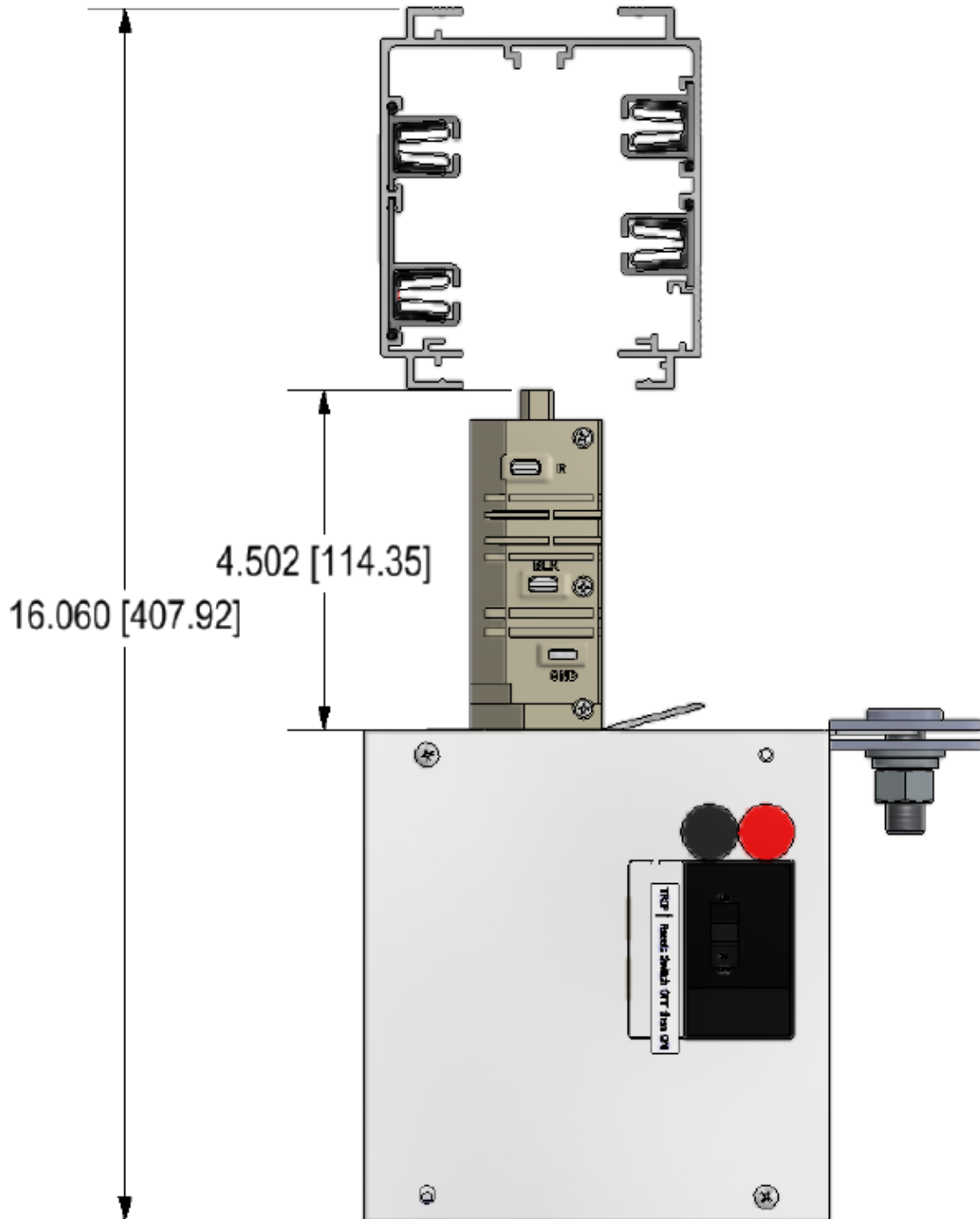

Enclosure E28

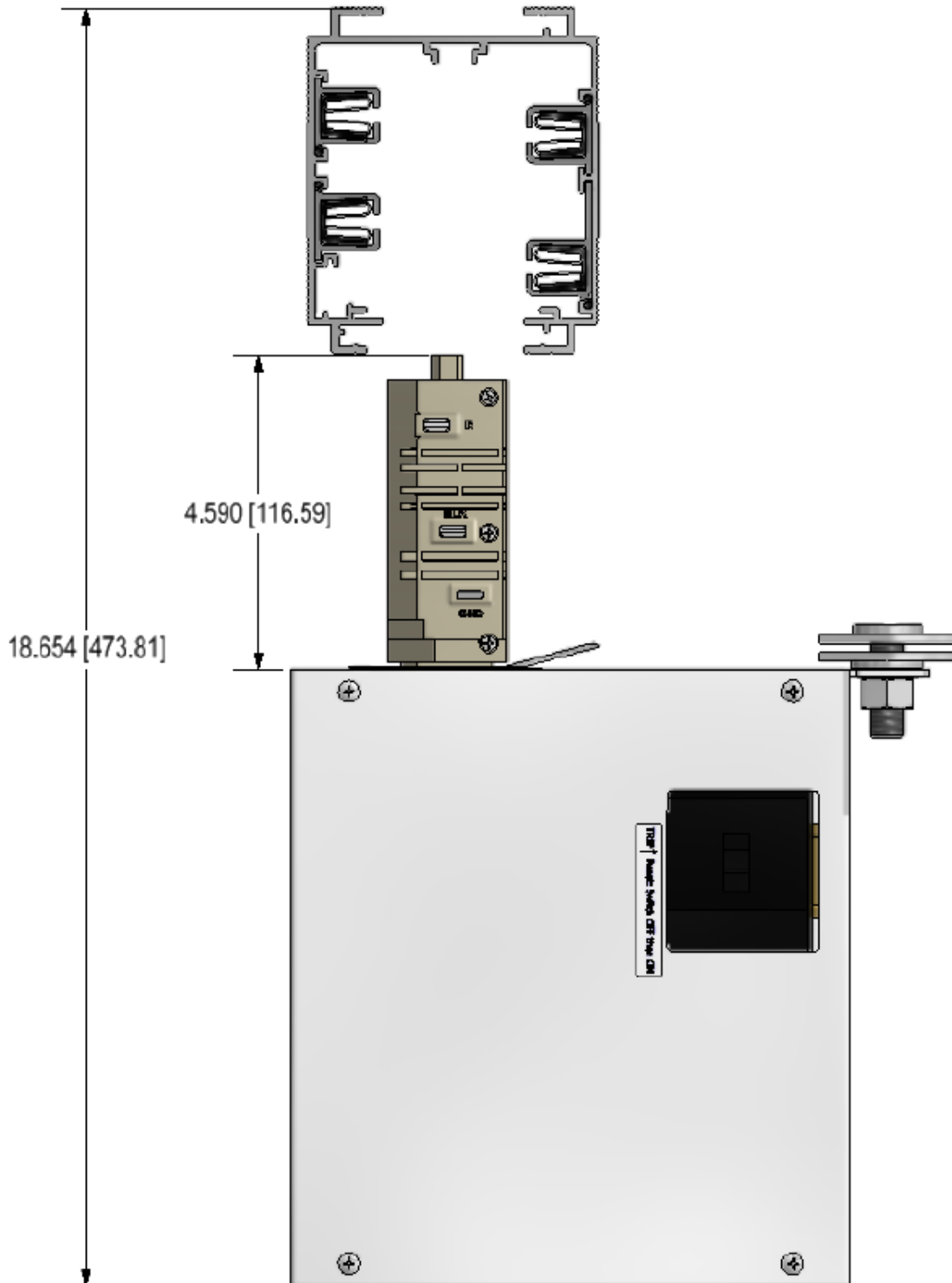

Enclosure E36

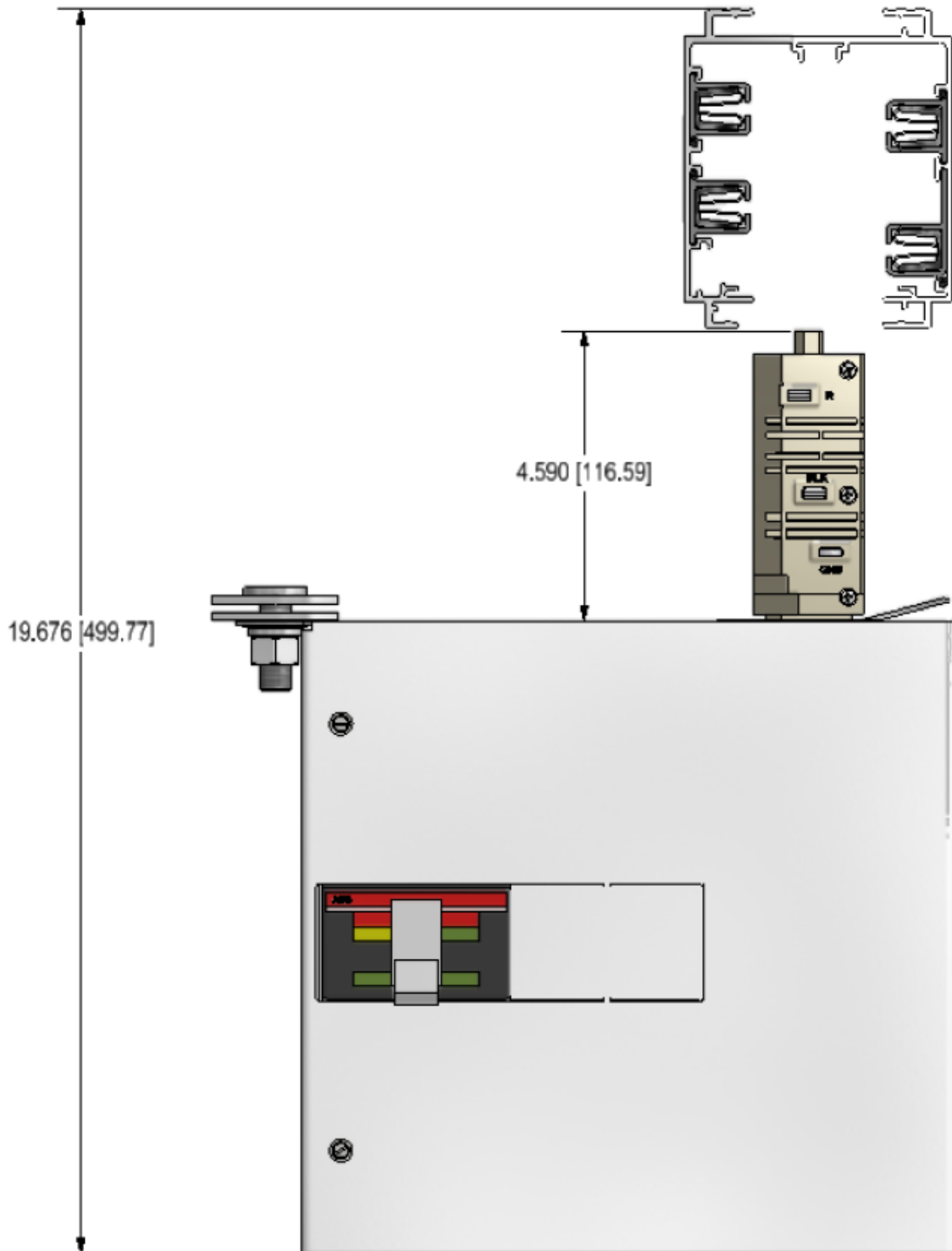

Enclosure E25

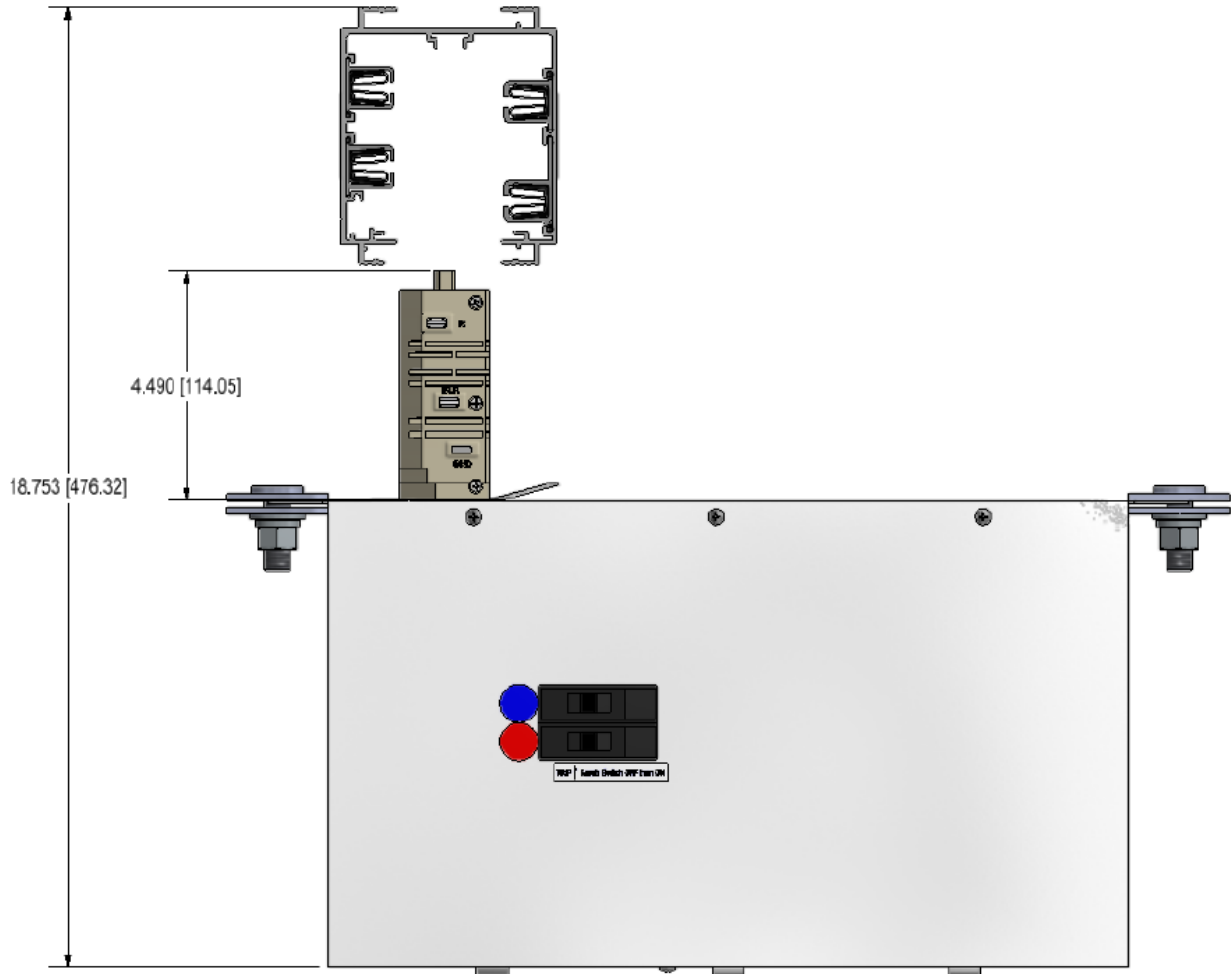

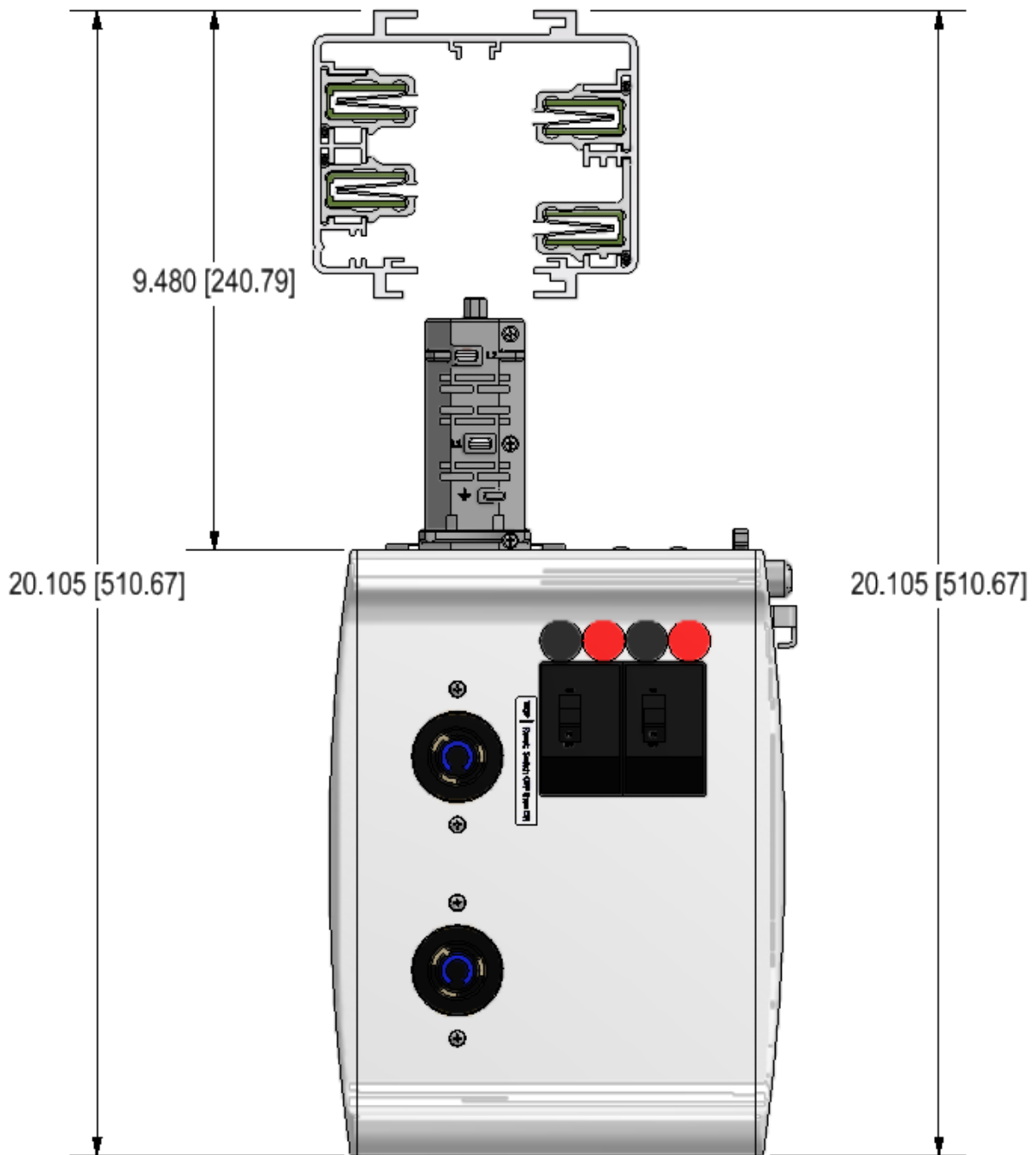

E50 Series Plug Shown

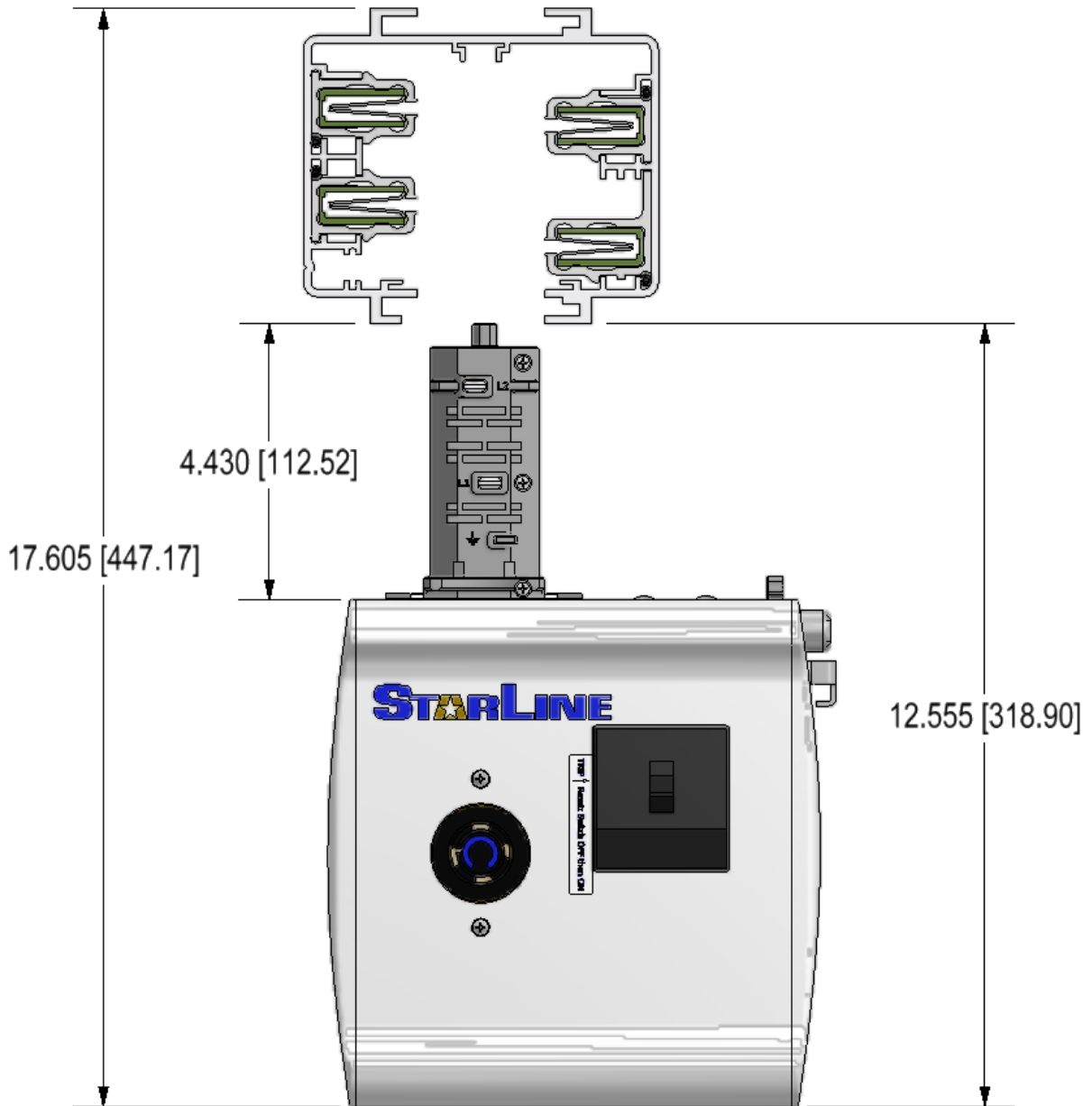

E90 Series Plug Shown

Section 5: Product Warranty Details

WARRANTY

Contractor/Customer: _____

Customer Order: _____

Seller warrants all products sold by Universal Electric Corporation to be free from defects in material or workmanship for a period of one year from the date of shipping. Seller's liability on this warranty shall be limited to the repair or replacement of any product which is returned to the Seller, within one year of the date of delivery and which is found by the Seller to be defective in material or workmanship. Customer must have written authorization prior to returning any material to Universal Electric. The Buyer will be responsible for the cost of removing and reinstalling a defective part(s) or its replacement and all labor and material and all other costs or expenses incurred in connection therewith.

Warranty Period: 1 year from shipment date _____

WARRANTY PROCESS

1. Customer calls either UEC Rep or UEC direct.
2. ISR will issue Return Material Authorization (RMA)
3. Customer returns warranted item along with copy of RMA.
4. UEC will either rework item or manufacture new item depending on the customer needs.
5. UEC ships item back to customer
6. UEC will determine reason for failure.
7. Corrective action will be documented.
8. If Reason for Failure is requested by customer. UEC will send report to customer.
9. All action items from corrective action report must be completed by assigned manager and returned to Quality Department.
10. Quality Department will track all warranted events and report them to the QA Team monthly.
11. Quality Department will report all warranties to Executive Team monthly.

Section 6: Maintenance

STARLINE BUSWAY RECOMMENDED MAINTENANCE

The Starline Busway was designed to be user friendly with no mandatory maintenance required. The joints, feeds, and plugs also require little to no maintenance. The design of the Starline Busway utilizes a boltless connection for the joining of the copper conductors. The connection is accomplished by the use of the unique design. The joint design uses a U-shaped conductor channel that utilizes a copper stab, or joint kit to connect two housing sections. This connection is mechanically pressed into the slot with the use of installation tools provided by UEC. This is a strong reliable Heat Tested connection, which requires no maintenance.

The housing couplers, end feed connections, mounting hardware, and hanger bolts can be checked at the user's discretion, but is not required by Universal Electric Corporation.

IR inspection of the end feed connections, joints, and plug-in units can be checked at the user's discretion, but is not required by Universal Electric Corporation.

We do recommend that the system be inspected periodically for physical damage or signs of any abnormalities.

- Refer to NEMA bulletin BU1.1 for general maintenance instructions.

TYPICAL BUSWAY COMMISSIONING PROCEDURES**Universal Electric Corporation**

The following document is not intended as a test requirement, but as a suggested check for the Electrical Contractor (Installer) and owner to verify proper installation of busway, joint kits, end or top feeders, and plug-ins before energizing the system.

1. Verify the proper busway was ordered and that it corresponds to the specific Bill of Materials (BOM) supplied by UEC.
2. Review the voltage and amp requirement of the system supplied, and verify that it corresponds to the initial Electrical Design from the Engineering Firm. (e.g. 208/120 Volts 225 amps Busway)
3. Review the installation instructions provided by UEC and verify the system was installed correctly. Be aware that the busway is polarized and has been installed accordingly, inspecting each joint for a proper connection.
4. Inspect that the connections at the End and/or Top feeds of the system are supplied with the proper cable, and verify that the voltage and cable size from the MDP panel corresponds to the Electrical Design.
5. Once the cable has been verified, confirm the cable connections to the lugs on the End or Top Feeds are secured and connected correctly to their corresponding Phase. (A, B, or C)
6. Make sure that all connections to Ground from the MDP panels to End or Top Feeds are secured and connected according to the Electrical Design. (IS-Isolated Ground, DG-Dedicated Ground, Case ground)
7. It is recommended to do a visual inspection of the installation, to make sure there are no loose parts or connections and that all of the critical components are in place and connected.
8. It is recommended that after the Busway and End Feeds are installed, and before energizing the system, a continuity test is performed to verify that all joint kits are installed properly, and that all phases and ground are connected properly.
9. Make sure that the voltage supplied for the Plug-ins Modules corresponds with the voltage supplied by the Busway.
10. Review the installation of the plug-ins, and verify they are facing the appropriate direction on the busway. Once orientation has been determined correct, check that all units have the breaker positioned off and the mounting hardware has securely fastened each unit.

11. It is recommended to perform a Megger Test before energizing the system. This test is to verify the condition of electrical insulation of the system, and to check the insulation resistance of the wiring to find out if there are shorts to ground in the system. Make sure you apply the proper voltage in order to prevent damage to equipment.
12. It is recommended to run a Load Bank Test; this test will accurately mimic the operation or “real” load that this system will run in its actual application, without running the risk of damaging the real equipment. It is recommended to do an Infrared (IR) Scanning of the entire system at this time. This is to ensure there are no defective components, loose connections, damaged switchgear or any other faulty electrical equipment.

Contact Universal Electric Corporation at 800-245-6378 with any questions.



For additional information regarding the STARLINE Track Busway 800T5 system, please visit:
<http://www.starlinepower.com/busway/products/250-400-800/>



168 Georgetown Road | Canonsburg, PA 15317 | +1 724-597-7800 | www.StarlinePower.com | info@uecorp.com